

# Qualifying SDH/SONET Transmission Path

**TABLE OF CONTENTS:**

<b>1.0 Transport Capability Tests</b>	<b>2</b>
<b>1.1 Mapping/Demapping Testing</b>	<b>2</b>
<b>1.2 BER Testing</b>	<b>2</b>
<b>2.0 Synchronization - Pointer Tests</b>	<b>3</b>
<b>3.0 Alarms/Errors Monitoring</b>	<b>4</b>
<b>4.0 Overhead Test</b>	<b>9</b>
<b>5.0 Measurements with CMA 5000 OTA</b>	<b>10</b>
<b>5.1 Mapping/Demapping Test</b>	<b>10</b>
<b>5.2 BER Testing</b>	<b>11</b>
<b>5.3 Synchronization - Pointer Tests</b>	<b>12</b>
<b>5.4 Quality Tests</b>	<b>13</b>
<b>5.5 Overhead Tests</b>	<b>15</b>
<b>6.0 Conclusion</b>	<b>16</b>

Installing, bringing into service or maintaining today's SDH/SONET networks requires specific tools.

All those who validate or operate SDH/SONET networks are faced with a number of tests that can be classified as shown below:

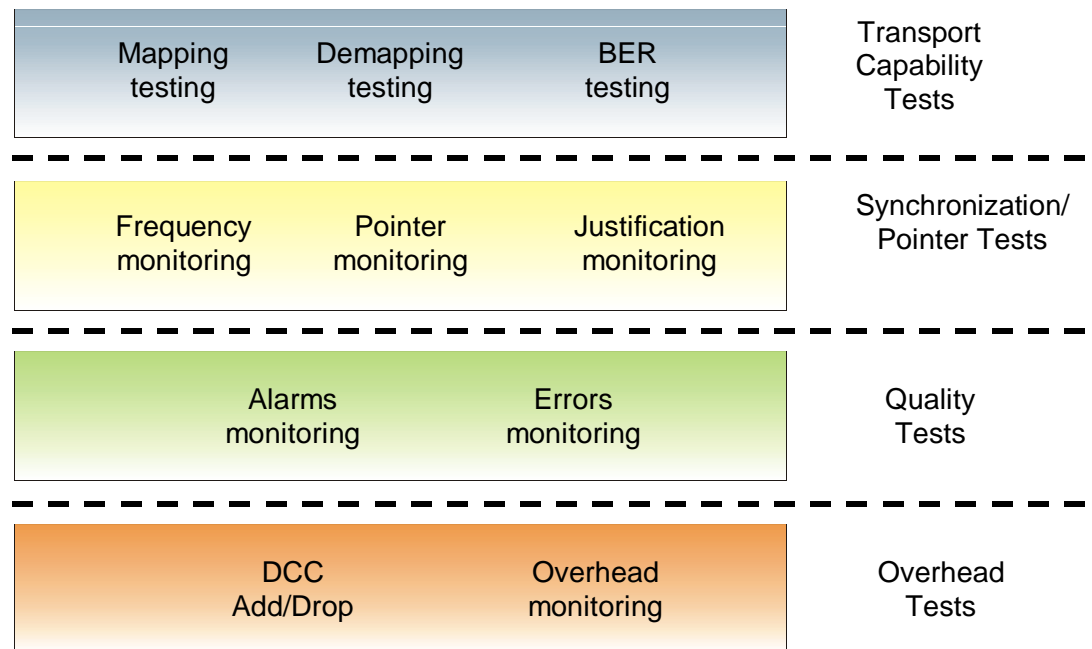

The purpose of this application note is to give an overview of each of these different tests and explain why they are important. In the last part of the document, we will see how you can benefit from CMA 5000 OTA capabilities for performing fast and accurate "path analysis".

## 1.0 Transport Capability Tests

### 1.1 Mapping/Demapping Testing

Multiplexer equipments are one of the base elements of the network.

The role of a multiplexer equipment is to insert low bit rate tributaries inside the SDH/SONET frame ("mapping" process) and conversely to drop the tributaries from the SDH/SONET frame ("demapping" process).

It is necessary to check that no error occurs during the mapping/demapping process and that the integrity of the tributary is guaranteed.

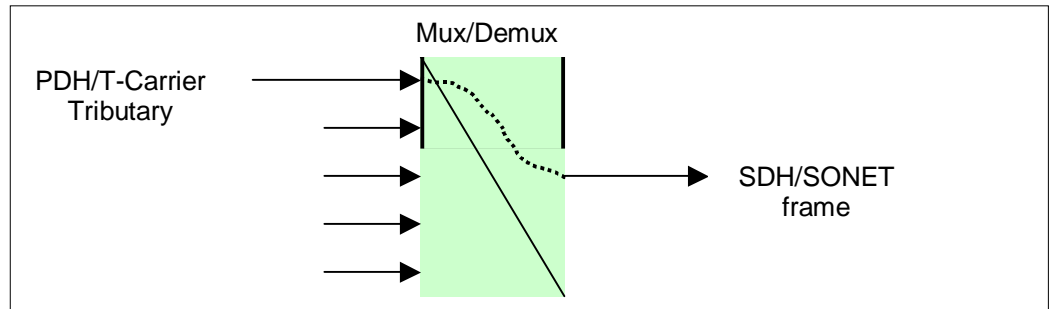

"Mapping" process

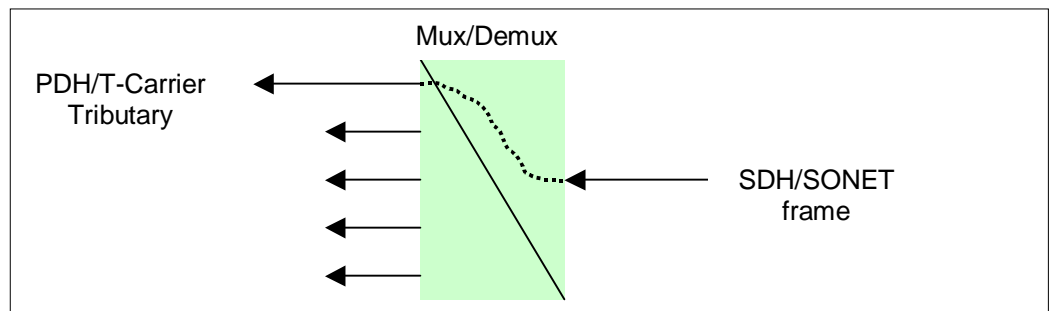

"Demapping" process

### 1.2 BER Testing

Bit Error Rate (BER) testing is the main part of Out-of-Service measurements. When the network is not in service yet (for example, during installation phase), it is nevertheless necessary to simulate customer traffic in order to check error free transmission before bringing the network into service.

In order to simulate customer traffic, a special pattern is generated:

- PRBS pattern (Pseudo Random Byte Sequence)

The BER testing consists of comparing bit by bit the received bytes sequence to the expected sequence and thus determining the number of errored bits received.

The ITU-T has defined different PRBS test signals (ex: PRBS-15, PRBS-23, etc). For example, a PRBS-15 signal is a set of consecutive words of 15 bits. This 15 bit word takes randomly all the possible values ( $2^{15}$  different words) between 000000000000000 and 111111111111111.

The ITU-T has established a correspondence between PRBS test signals and the transmission rate. The recommendations assign longer sequences to higher transmission rates (see table below):

	Recommendations	Bit Rate	Test Sequence
PDH/T-Carrier	0.150 to 0.153	E1	PRBS-15
		DS1	PRBS-15
		E3	PRBS-23
		DS3	PRBS-23
		E4	PRBS-23
Virtual Containers / Synchronous Payload Envelope (SPE)	0.181	VC4	PRBS-23
		VC4-4c	PRBS-23
		VC4-16c	PRBS-23
		VC4-64c	PRBS-23
		STS3c-SPE	PRBS-23
		STS12c-SPE	PRBS-23
		STS48c-SPE	PRBS-23
		STS192c-SPE	PRBS-23

## 2.0 Synchronization - Pointer Tests

The particularity of SDH/SONET networks is that they are ‘Synchronous’ networks. That means all signals carried through the network must travel at a standard rate, which may vary slightly within a margin, defined by ITU-T and ANSI recommendations.

Even if in theory the network can bear a small difference between the specific nominal value of the signal and the real rate, it is necessary to measure the line frequency, because excessive variation may generate impairments:

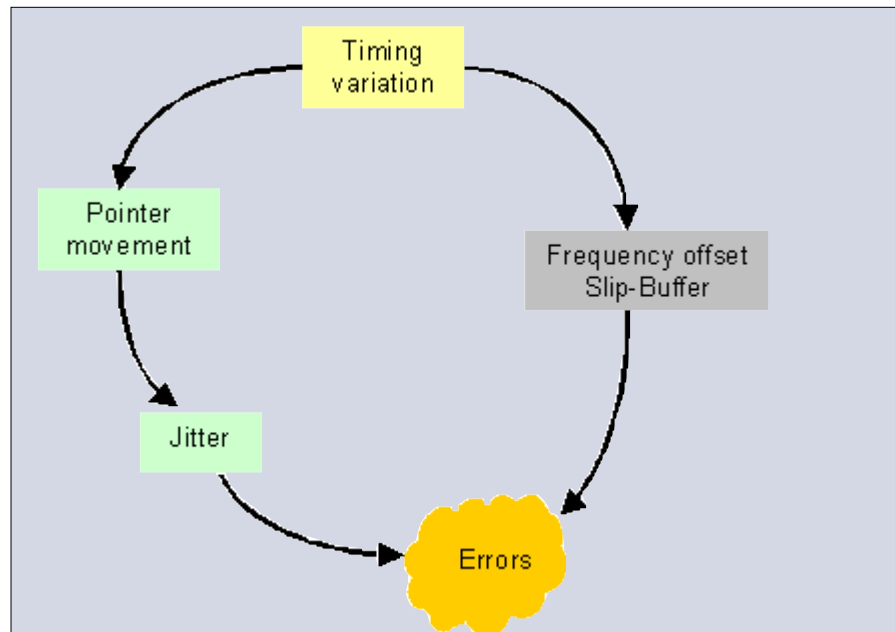

ITU-T and ANSI have defined special test sequences in order to stress the network with different pointers movements.

The 4 main sequences are described below:

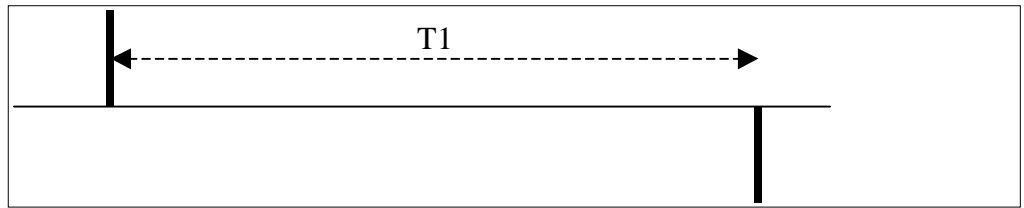

Independent pointers with opposite polarity

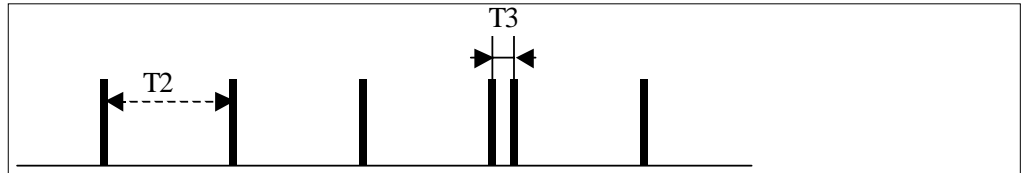

Pointers at regular intervals with double pointer

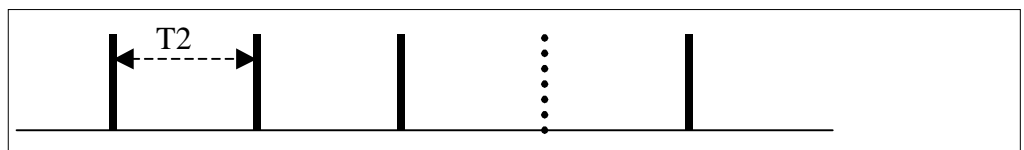

Pointers at regular intervals with missed pointer

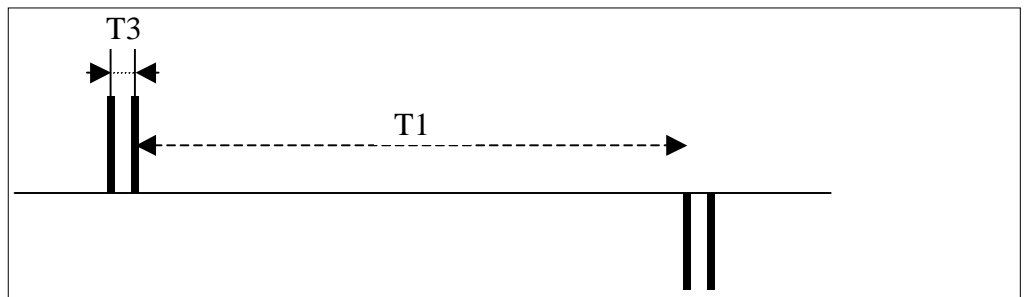

Double pointer with opposite polarity

### 3.0 Alarms/Errors Monitoring

For In-Service SDH/SONET monitoring, the network uses special mechanisms for checking the integrity of the frame at different levels:

SDH Frame	SONET Frame
Regenerator section	Section part
Multiplexing section	Line part
Virtual Container (High Path)	Synchronous Payload Envelope: SPE (High path)
Virtual Container (Low Path)	Synchronous Payload Envelope: SPE (Low Path)
Tributary	Tributary

The general monitoring mechanism is shown below:

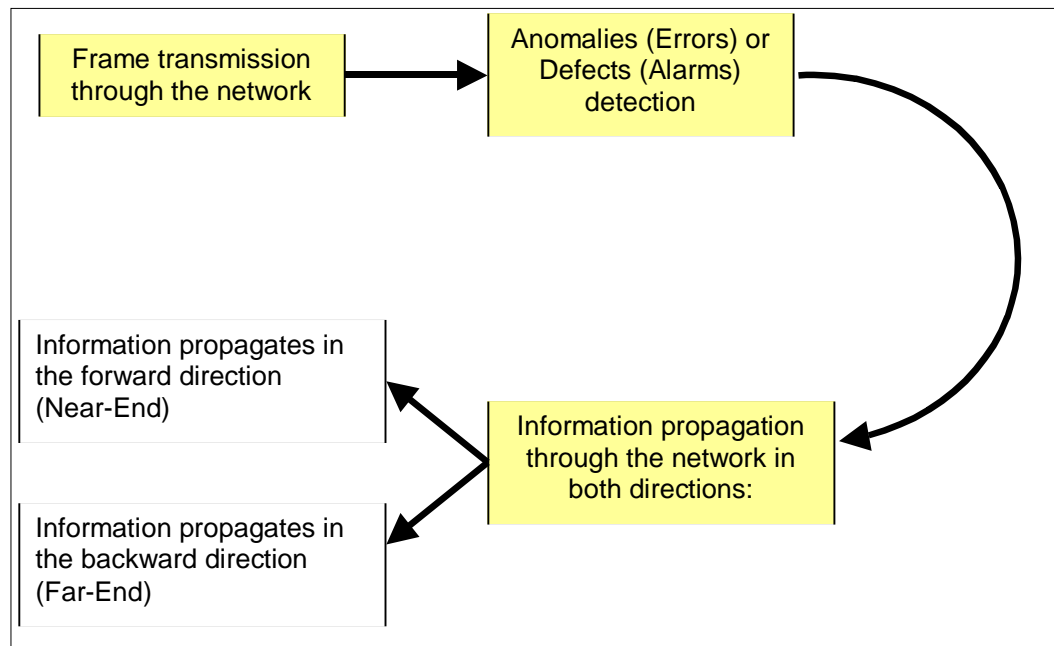

SDH/SONET network monitoring mechanism

By passing through the network, each part of the SDH/SONET frame is monitored by dedicated bytes. The table below gives an example of the associated bytes for SDH/SONET frames, which are used to monitor the errors (anomalies):

Byte	Portion of the frame monitored (SDH)	Portion of the frame monitored (SONET)
B1	Complete frame	Complete frame
B2	SDH frame without Regenerator section	SONET frame without Section portion
B3	Virtual Container (VC4, VC3) High Path	Synchronous Payload Envelope: STS-SPE
V5	Virtual Container (VC11, VC12) Low Path	Synchronous Payload Envelope: VT 1.5-SPE

Different portions of the network, physically manage the various bytes in order to easily identify and sectionnalize the origin of the problems:

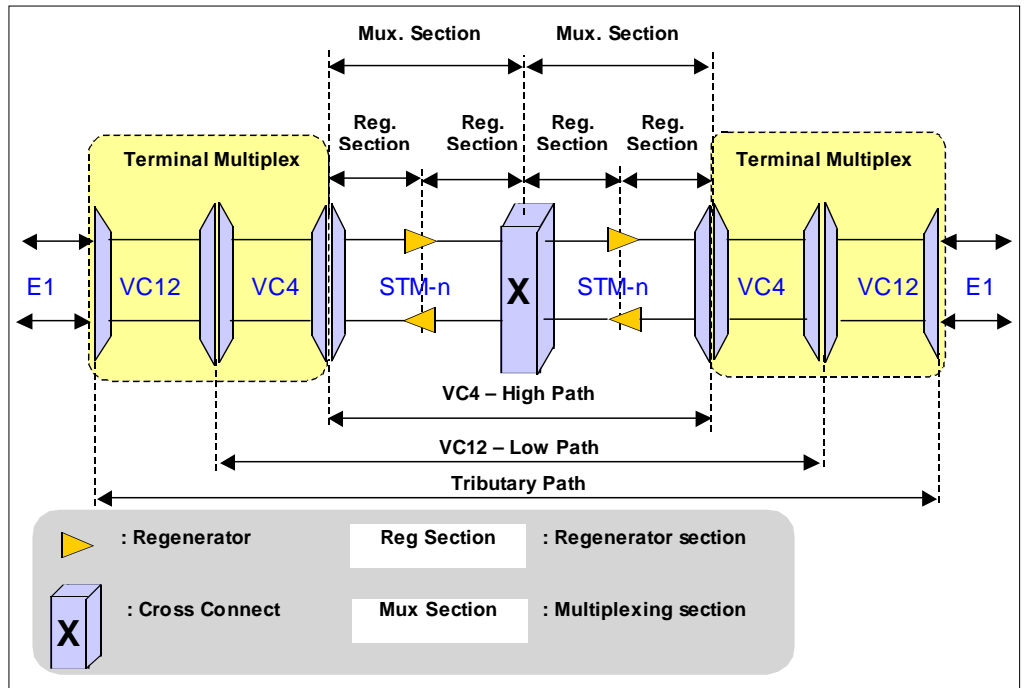

SDH architecture network

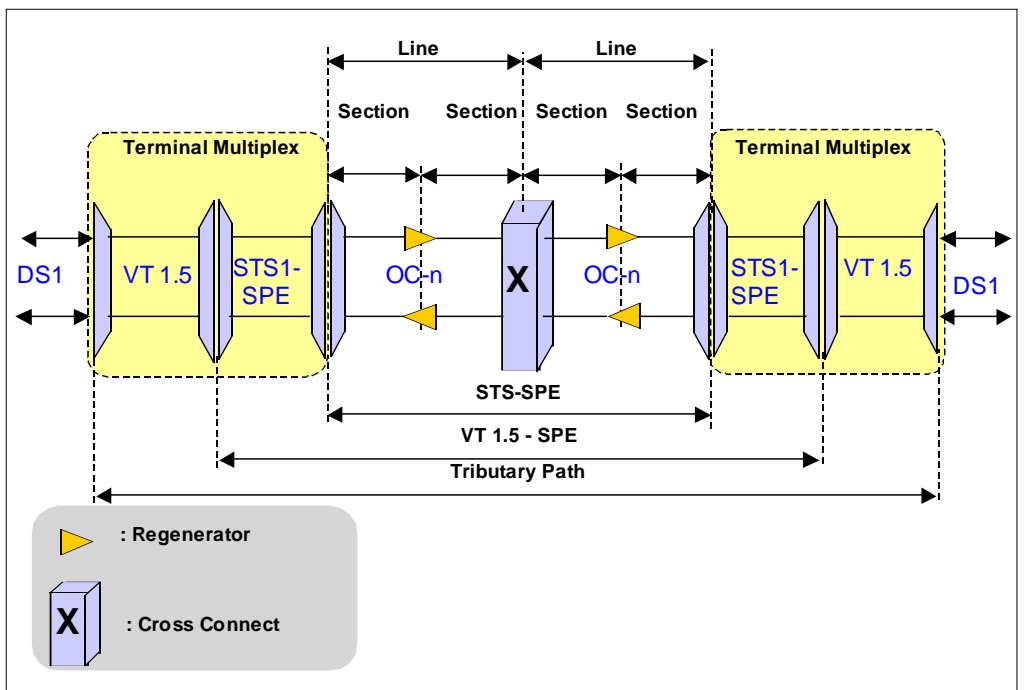

SONET architecture network

**Vocabulary:**

**Regenerator Section (in SDH) or Section (in SONET)** is the basic segment of the SDH/SONET network. It is the smallest entity that can be managed by the system. Each repeater monitors defects such as Loss Of Signal, Loss Of Frame, B1 errored blocks... By passing through a repeater, the R-SOH is fully recalculated.

**Multiplexing Section (in SDH) or Line (in SONET)** is the entity delimited by 2 equipments that process the payload of an STM-N/OC-N frame. It detects defects and errored blocks and generates special alarms in the forward and backward directions. It manages the Automatic Protection Switching with K1 and K2 bytes. It regenerates a complete SOH.

**VC4 High Path (in SDH) or STS-SPE (in SONET)** is an entity that transports a C4 container or a Synchronous Payload Envelope (SPE) from one end of a network to the other. A VC4 or STS-SPE can be affected to one customer.

**VC12 Low Path (in SDH) or VT 1.5-SPE (in SONET)** is an entity that transports a C12 container or a VT 1.5 Synchronous Payload Envelope (SPE) from one end to another end of a network. A VC12 or VT 1.5-SPE can be assigned to one customer.

When a problem is detected, information is sent to the network as follows:

- in red: Alarm detection and propagation
- in blue: Error detection and propagation

Generally speaking, when an alarm is detected, all the network equipments in the forward direction are informed via the propagation of an AIS alarm (Alarm Indication Signal). The network equipments in the backward direction are also informed by receiving a special alarm called RDI (Remote Defect Indication).

When an anomaly (error) is detected, the network equipments in the backward direction are informed by receiving a special error parameter called REI (Remote Error Indication).

The information generated in the forward direction is also called NEAR END parameters. The information generated in the backward direction is also called FAR END parameters.

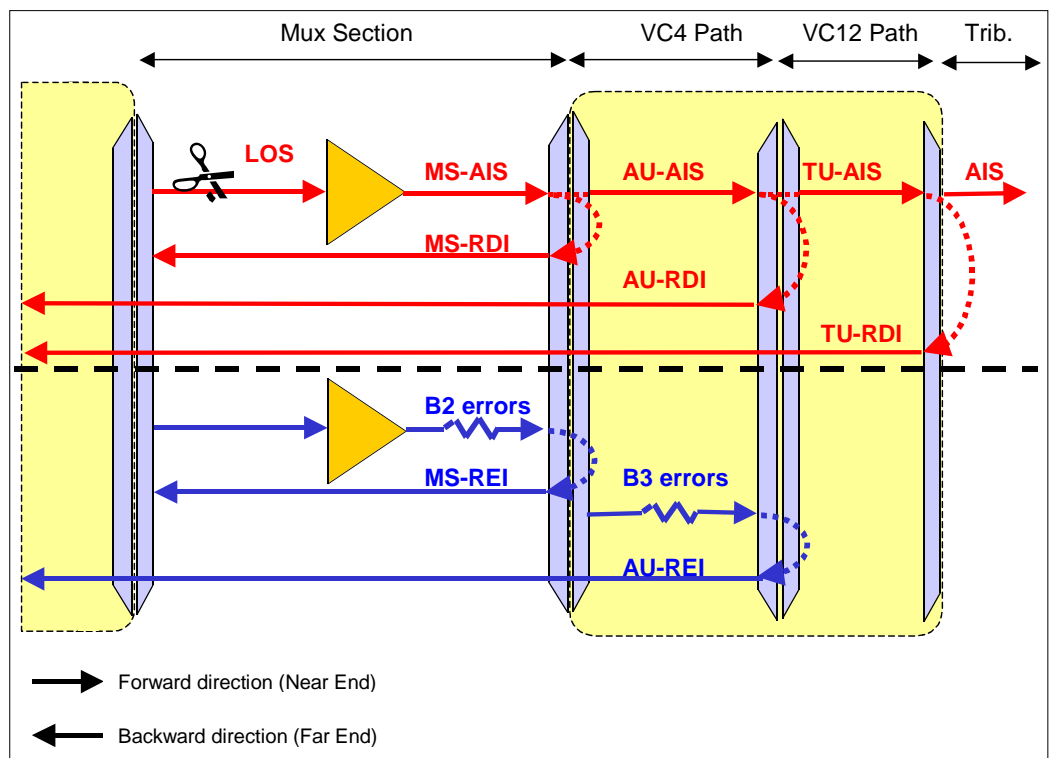

SDH alarm/error propagation

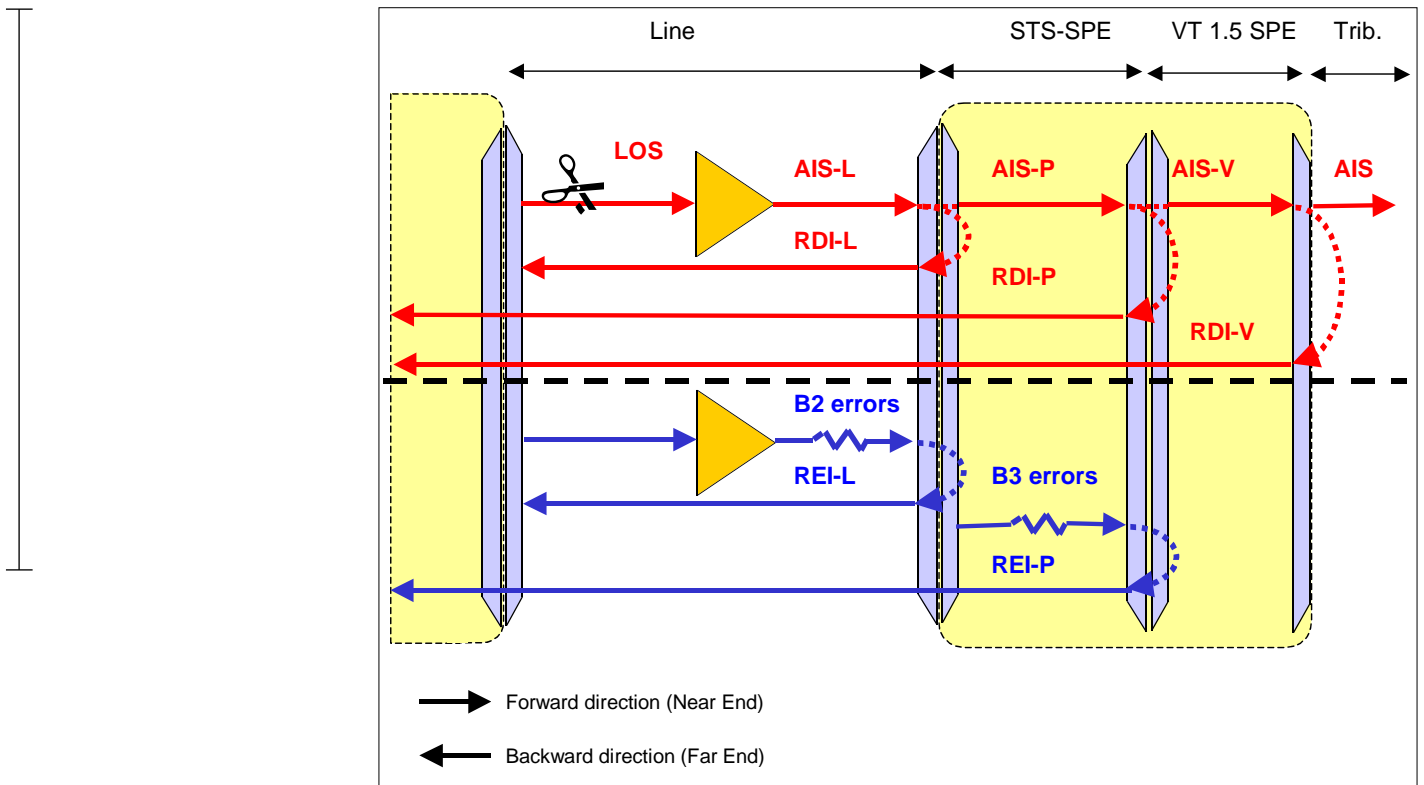

SONET alarm/error propagation

The general table of alarm/error propagation is given below:

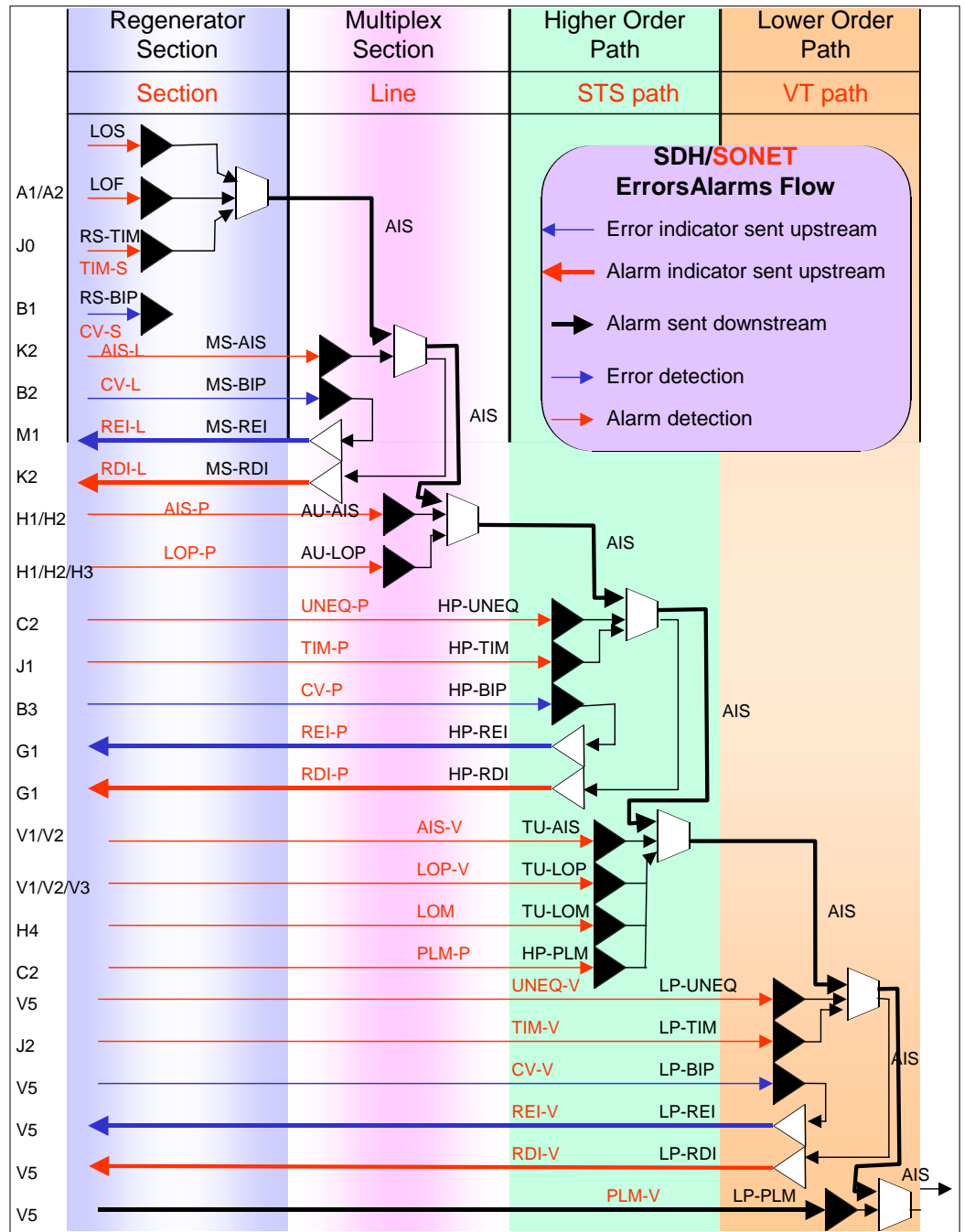

#### 4.0 Overhead Test

The different overheads of the SDH/SONET frames carry a lot of important information. For example:

- J0 message: frame identifier - Section trace
- S1 byte: synchronization status byte
- J1 message: VC4 or STS-SPE Path Trace
- C2 byte: signal label
- J2 message: VC12 or VT 1.5 SPE Path Trace

It is very important to have all the details of this information available in real time as:

- The removal of the state telecommunication monopoly in many countries has lead to a rapid increase in the number of domestic network operators and services providers.
- Not all of these competing network providers can achieve complete coverage with their own backbone networks.
- Particularly for long-distance traffic, they tend to lease transport capacity from competitors (ex: mobile radio operators).

**All of these factors are creating more and more complex network environments with many network interconnections.**

**Correct analysis of the specific signal to be tested is guaranteed by comprehensive decoding and controlling of the frame overhead.**

## 5.0 Measurements with CMA 5000 OTA

### 5.1 Mapping/Demapping Test

OTA Applications enable you to configure transmission and reception independently. For example, it is possible to generate an STM16/OC-48 signal and simultaneously to analyze an E1/DS1 frame.

With only one CMA 5000 tester, you can test the mapping/demapping process of your multiplexer.

#### How to configure OTA?

- Select "Path Analysis" measurement with the "Select Measure" button.
- Open the "Tx" window and deselect the "Auto-Coupling" function. When this option is not selected, the transmission and the reception can be configured independently:

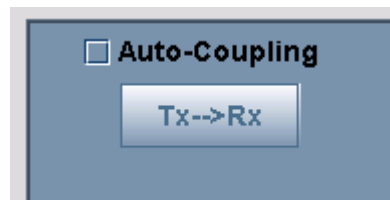

Deselect the Auto-Coupling option

Mapping Test Example

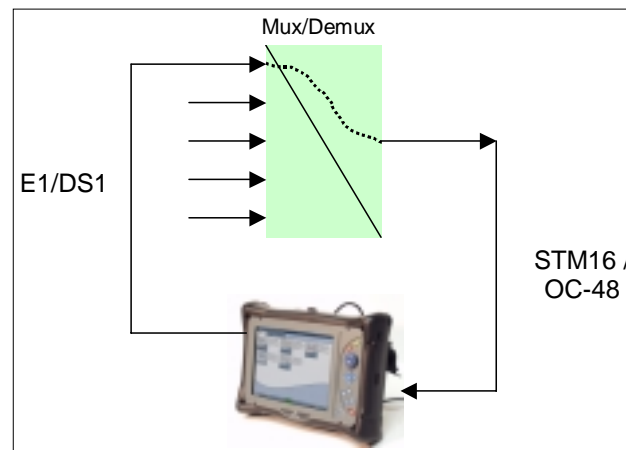

## 5.2 BER Testing

All the test sequences defined by ITU-T and ANSI recommendations are available in OTA Applications.

In fact, OTA provides more PRBS sequences in order to test the network in the worst situations.

### How to configure OTA?

- Open the "Tx" window
- Select the tributary (PDH/T-Carrier tributary or concatenated payload)

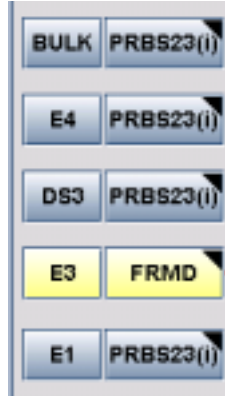

- Touch the tributary payload button in order to open the payload editor
- Select the PRBS sequence

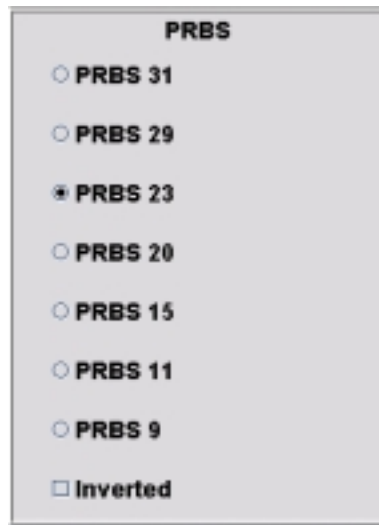

- On the receiver's side, the OTA Application analyzes and displays the BERT result in the "Quality" window:

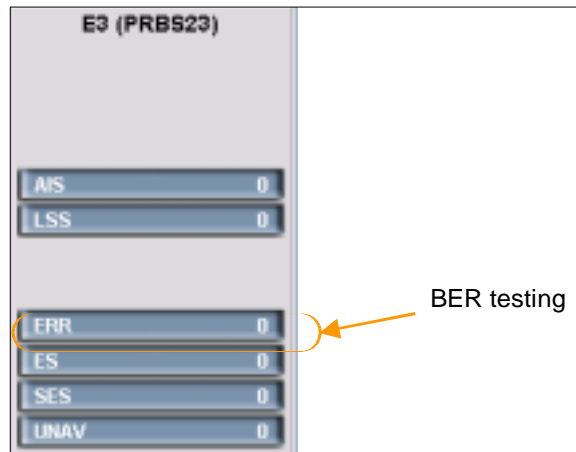

### 5.3 Synchronization - Pointer Tests

OTA Applications provide a complete set of test functions for checking the synchronization mechanisms of the network:

- Generation and analysis of the frequency line offset
- Generation and analysis of the pointer movements
- Jitter/Wander possibilities are described in another application note dedicated to Jitter/Wander measurements

#### Generation and analysis of the frequency line offset

- Open the Stress menu with the "Stresses" button
- Select the "Frequency" menu. The following window appears:

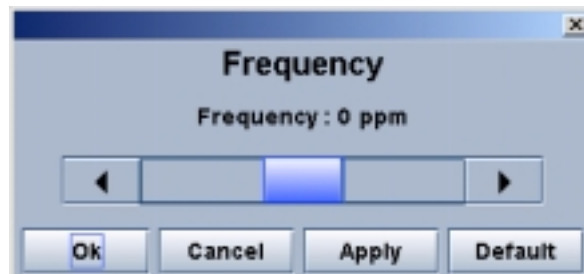

You can generate a frequency offset of ~30 ppm or ~100 ppm (depending on the configuration)

- On the receiver's side, the OTA Application displays the frequency line offset in the "Quality" window:

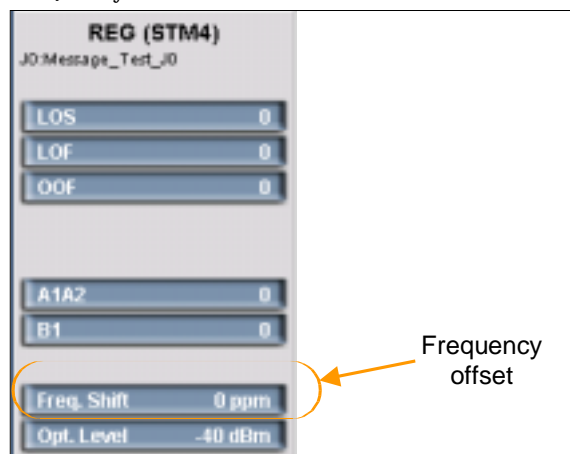

## Generation and analysis of the pointer movements

- Open the Stress menu with the “Stresses” button
- Select the menu corresponding to the pointer you want to stress (For example, “AU4 pointer” or “STS-SPE pointer”)

A window (depending on your choice) appears:

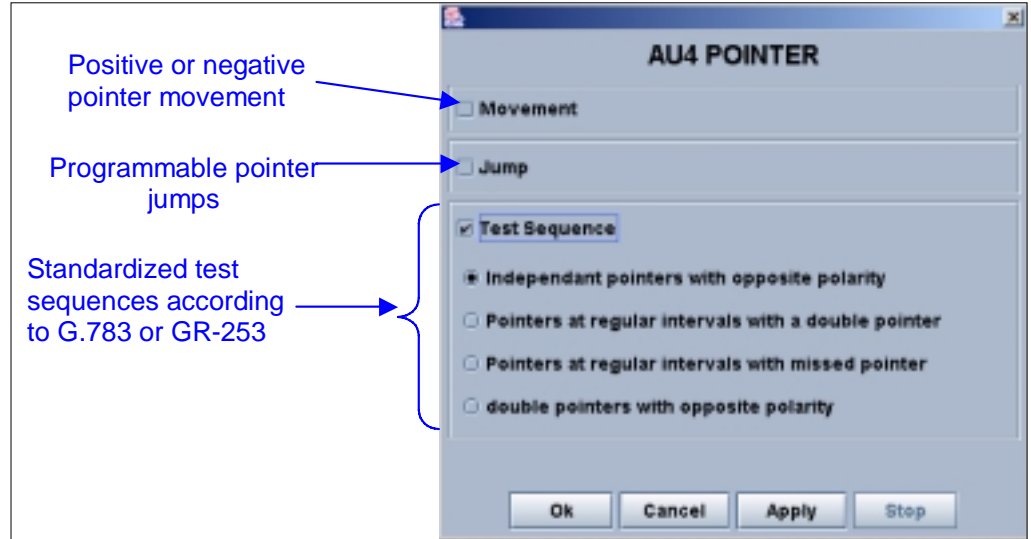

- On the receiver’s side, the OTA Application displays all the information concerning the different pointers in the “Quality” window:

AU4 Pointer		TU3 Pointer		JUSTIF	
Value	526	Value	0	Frequency	0 ppm
Neg	0	Neg	0	Neg	0
Pos	0	Pos	0	Pos	0
NDF	0	NDF	0		

## 5.4 Quality Tests

The OTA Application provides a very powerful function to check the transmission quality of the network.

The OTA Application displays in one single window all the information regarding the measurement:

- Errors
- Alarms
- Quality parameters (G.826, etc...)
- Pointer values
- Justification
- Received Optical level and Frequency Offset

All this information is broken down to facilitate the interpretation of the results. To view the information, touch the “Quality” tab:

Clear view of the results

REG (STM4)	MUX	VC4	VC3	B3 (PRB323)
J0:Message_Test_J0	S1:0000 Quality unknown	J1:Message_Test_J1 C2:F0h 0.18 signal testing	J1:Message_Test_J1 C2:F0h 0.18 signal testing	
LOS 0	MS-AIS 0	AU-AIS 0	TU-AIS 0	AIS 0
LOF 0		AU-LOP 0	TU-LOP 0	LSS 0
DOF 0		HP-SLM 0	LP-SLM 0	
A1A2 0	B2 0	HP-UNEQ 0	LP-UNEQ 0	
B1 0	ES 0	B3 0	LP-B3 0	ERR 0
Freq. Shift 0 ppm	SES 0	ES 0	ES 0	ES 0
Opt. Level -33 dBm	UNAV 0	SES 0	SES 0	SES 0
	MS-RDI 0	UNAV 0	UNAV 0	UNAV 0
	MS-REI 0	AU-RDI 0	TU-RDI 0	
	ES 0	AU-REI 0	TU-REI 0	
	SES 0	ES 0	ES 0	
	UNAV 0	SES 0	SES 0	
		UNAV 0	UNAV 0	
	APS	AU4 Pointer	TU3 Pointer	JUSTIF
	Switch 0	Value 526	Value 0	Frequency 0 ppm
	Duration 0.000 ms	Neg 0	Neg 0	Neg 0
		Pos 0	Pos 0	Pos 0
		NOF 0	NOF 0	

All the results are broken down section by section.

For each section, the forward (near end) parameters and the backward (far end) parameters are clearly identified. Example:

**VC4**

J1:Message\_Test\_J1  
C2:F0h 0.18 signal testing

Forward parameters  
(Near End)

AU-AIS 0

AU-LOP 0

HP-SLM 0

HP-UNEQ 0

B3 0

ES 0

SES 0

UNAV 0

Backward parameters  
(Far End)

AU-RDI 0

AU-REI 0

ES 0

SES 0

UNAV 0

## Generating calibrated stresses

In order to validate the network (for example the network management system), it is necessary to generate calibrated alarms and errors and check how the network reacts to this stress. With OTA Applications, a complete choice of alarm/error generation is available.

- Open the Stress menu with the “Stresses” button
- Select “Alarm/Error” menu. The following window appears:

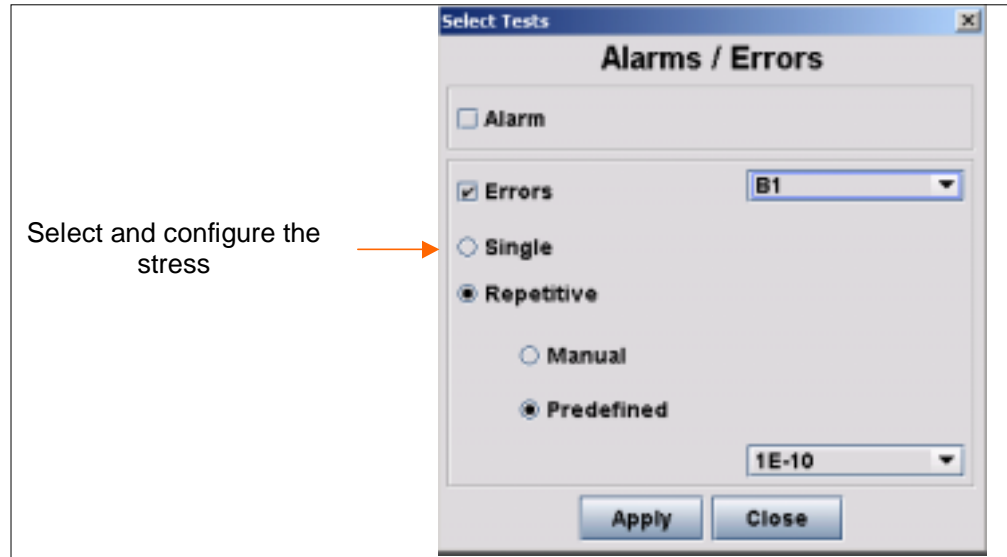

## 5.5 Overhead Tests

With the “Quality” and “Capture” windows, the OTA Application gives direct access to overhead monitoring.

- In the “Quality” window, all the significant overhead bytes are displayed in ASCII format and are refreshed in real time during the measurement:

REG (STM4)	MUX	VC4	VC3
J0:Message_Test_J0	S1:0000 Quality unknown	J1:Message_Test_J1 C2:FEB 0.101signal testing	J1:Message_Test_J1 C2:FEB 0.101signal testing

- In the “Capture” window, the SOH/TOH and POH bytes are displayed in hexadecimal form. The capacity of the capture function is 64 frames. For easier interpretation of the results, the value of the bytes with a fixed value is displayed in black, and the value of the bytes with a changing value is displayed in red.

- Touch the "Capture" tab to display the following window:

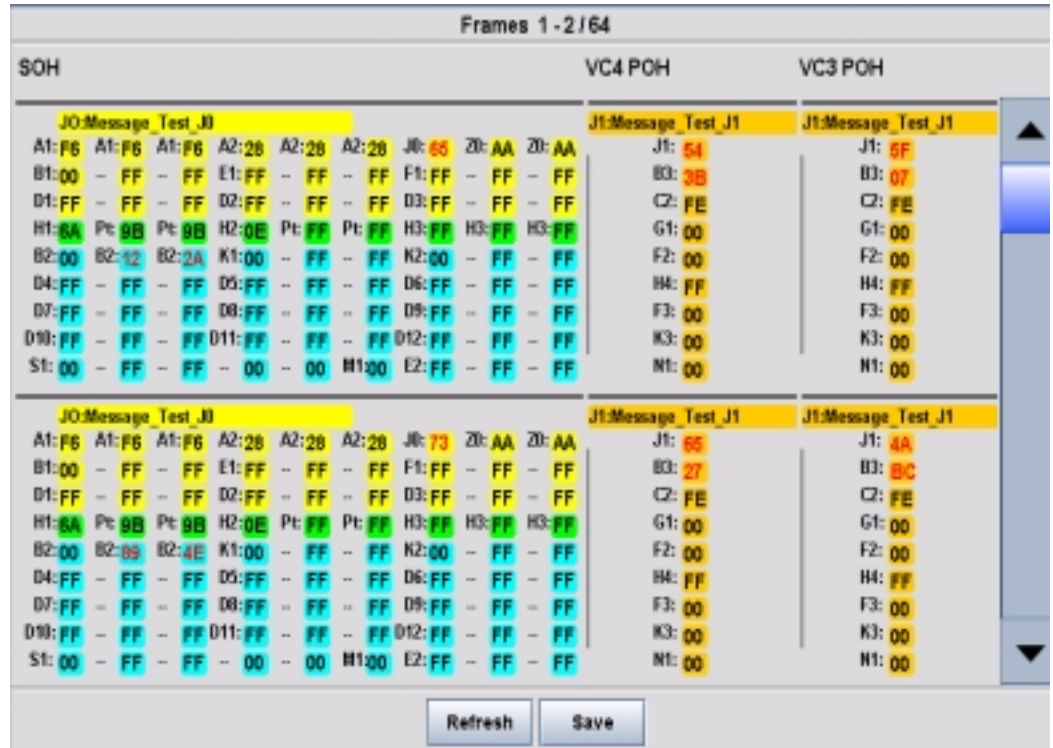

- DCC Drop/Insert

The Data Communications Channel (DCC) carries data that enable OAM (Operation, Administrative & Maintenance) communications between network equipments.

There are 2 DCC channels.

The first DCC channel is composed of the bytes D1-D2-D3 (located in the Regeneration Section (SDH) or Line part (SONET) of the frame). The bit rate is 192 Kbit/s for this channel.

The second DCC channel is composed of the bytes D4 to D12 (located in the Multiplexing Section (SDH) or Section part (SONET) of the frame). The bit rate is 576 Kbit/s for this channel.

The CMA 5000 OTA Application enables you to insert external data into the D1-D3 channel and/or D4-D12 channel (via the DCC connector present in the front panel of the OTA module (DB 15 connector)).

On the receiver's side, the DCC data automatically drop out and are available via the same DCC connector.

To configure the external DCC Drop/Insert, open the "Tx" window and select "SOH" or "TOH". Then select "External DCC".

## 6.0 Conclusion

All the functions necessary to qualify or maintain the network are present in one single analyzer.

In addition, other kinds of specialized measurements are available with the CMA 5000 OTA Application: Round Trip Delay, Automatic Protection Switching...

These details are described in other application notes.



### NetTest A/S

Kirkebjerg Alle 90  
DK-2605 Brøndby  
Denmark  
Tel: +45 72 11 23 00  
Fax: +45 72 11 22 77  
E-mail: nordic@nettest.com

### NetTest Sales Offices

Australia	+61 3 9890 6677	Italy	+39 02 95 12 621
Brazil	+55 11 5505 6688	Mexico	+52 5557 8249
Canada	+1 905 479 8090	Singapore	+65 6220 9575
China	+86 10 6467 9888	Spain	+34 91 372 92 27
Denmark	+45 72 11 23 00	Sweden	+46 8 555 410 65
France	+33 1 61 34 34 61	UK	+44 (0)1883 349 110
Germany	+49 89 99 89 01 0	USA	+1 315 266 5000

NetTest, the pioneer in multi-layer network testing, is a global provider of test and measurement systems, instruments and components for all types of networks and all stages of network development and operation. Our solutions offer leaders in optical, wireless and fixed networking vital insights into network performance, enabling informed business decisions that drive profitability.